

Designed for **winners**



Rapid **150 Series**

Injection moulding

# Winning demands performance



Being good just isn't good enough when it comes to winning in today's highly competitive world. Even small improvements mean the difference between being the leader or being forgotten.

It's the same with granulators. Our installed base of more than 20,000 units confirms that the Rapid 15 Series is the leading low-speed granulator range in the world.

But that's not good enough for Rapid. We're innovators and we accept no compromises. That's why we have developed a new generation of small-sized granulators with a unique design concept, more options, and a technical superiority that put us way ahead of the competition.

We call it the Rapid 150 Series.

*"The Rapid One-Fifty Series is designed for winners. Join us and lead from the start."*

# more than good

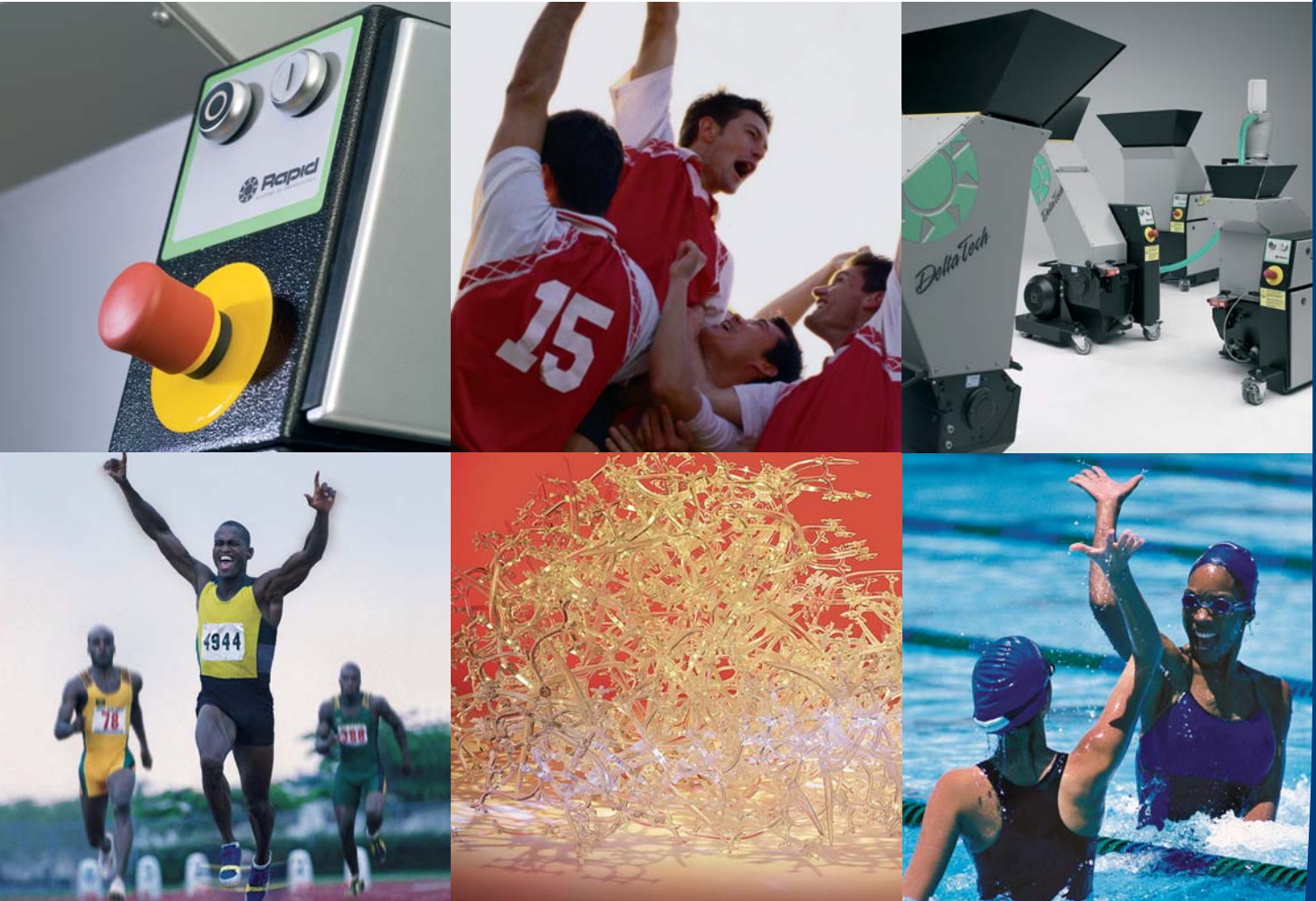

## Rapid – the most trusted name in granulators

Rapid is dedicated to partnering with its customers and taking good care of them. We have the technological leadership needed to carry out the continuous improvements in design and performance that drive granulator evolution. Only the highest-quality materials are used to ensure you get the most rugged and most dependable granulators available.

This is why we proudly state that Rapid is the most trusted name in granulators:

- a 5-year warranty program
- world leader in granulator solutions
- more than 60,000 Rapid granulators delivered over 40 years
- 24/48-hour spare parts service
- focused strategy in granulator solutions only

# Tailor-made solutions that cover all your needs

If you want a tough machine or an extremely tough one, no problem, we've got both – Rapid 150 DeltaTech and Rapid 150 PowerTech. And no matter how your injection moulding machines are configured, we have the right beside-the-press or under-the-press models for you.

Different infeed options are available that allow either manual or automated waste input. For all Rapid 150 models, a closed-loop granule transport system can be integrated with a granulator to recycle regrind directly back to the injection moulding machine.

## Higher regrind quality and accessibility



The first priority for our customers is high regrind quality, for which Rapid has always provided superior technology.

Easier access to all machine parts for cleaning and maintenance is another key benefit.

## CleanGRIND

Cutting Technology

Consistent size of regrind with fewer fines that melt more uniformly result in less rejected parts and reduced costs.

## VersaGRIND

Technology

Mix and match from an array of standardized components to create the Rapid 150 Series granulator that exactly fits your application needs.

## EasyCLEAN

Engineering

Both the hopper and screen cradle of the Rapid 150 Series are easily opened and closed to provide simple access for cleaning and maintenance.

## Rapid 150 PowerTech – Super strength and performance

The “no compromise” approach to Rapid 150 PowerTech has resulted in unmatched cutting power for a granulator dedicated to making light work of hard, filled and abrasive materials.

Knives made from specially treated high-alloy steel have boosted their lifetime 13 times compared with earlier knives! And all the reinforced parts in this model add up to minimal service and maintenance. No wonder it's the top-of-the line superman.

## Rapid 150 DeltaTech – Widest choice of size and capacity

The seven different Rapid DeltaTech models provide the widest choice of size, capacity and options needed for customization. Numerous configurations are facilitated with optional hoppers, and various infeed and vacuum discharge systems. Both auger and docking models are now even lower to fit more easily under a press.

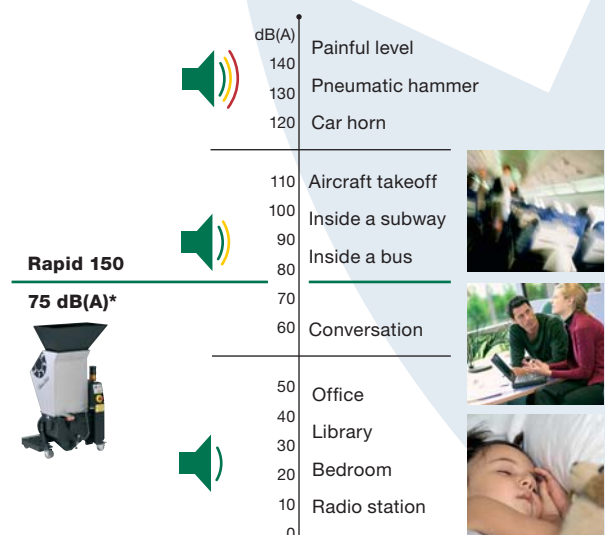

Rapid 150 PowerTech and Rapid 150 DeltaTech granulators have been developed for quieter operation, even without the optional soundproofing hood.

\* Depending on material, feed rate, etc.



150-07

150-21

150-35

150-42

## Rapid 150 PowerTech for the toughest jobs

- Toughness
- Flexibility
- Regrind quality
- Noise



150-07

150-21

150-35

150-42



150-21 A

150-21 D / 150-35 D

## Rapid 150 DeltaTech for demanding needs

- Toughness
- Flexibility
- Regrind quality
- Noise

# Outstanding features that make you a winner

## Superior regrind quality

- CleanGrind Cutting Technology
- Constant cutting circle
- Rotating shaft endplates

## Minimal dust in the environment

- CleanGrind Cutting Technology
- Dust-sealed granule bin
- Improved sealing between the hopper frame and the cutterhouse

## Greater durability

- Rotor bearing with higher load factor
- Bearing housings with greater wear resistance
- Hardened cutter ring as standard
- Hardened and turnable screen as standard

## Easier accessibility

- A single safety switch and safety screw
- Lower inlet height for the auger/docking models
- Slotted guide for the screen box
- Better mobility on castors
- Optimal cassette knife-changing system

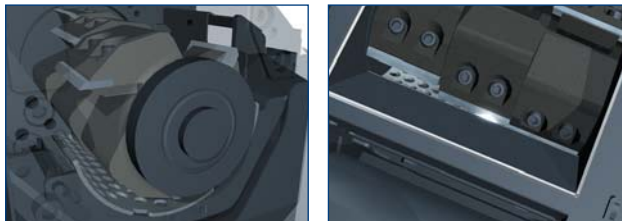

*Durability – solid staggered rotor design with smooth scissor-cutting action.  
Rapid cassette knife system – eliminates resharpening and adjustments.*



*Easy service/cleaning – instant access to rotor and cutterhouse.*

## Safer granulation

- Oversized bearings with high load factors are standard to help eliminate bearing failure – particularly important when granulating thick, hard, filled and/or abrasive materials.
- Flyback trap to prevent plastic waste from bouncing out of the infeed hopper.
- Low noise level in general and with soundproofing hood in particular.

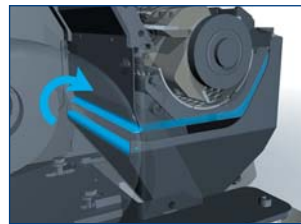

*Clean environment – dust-sealed granule bin.*

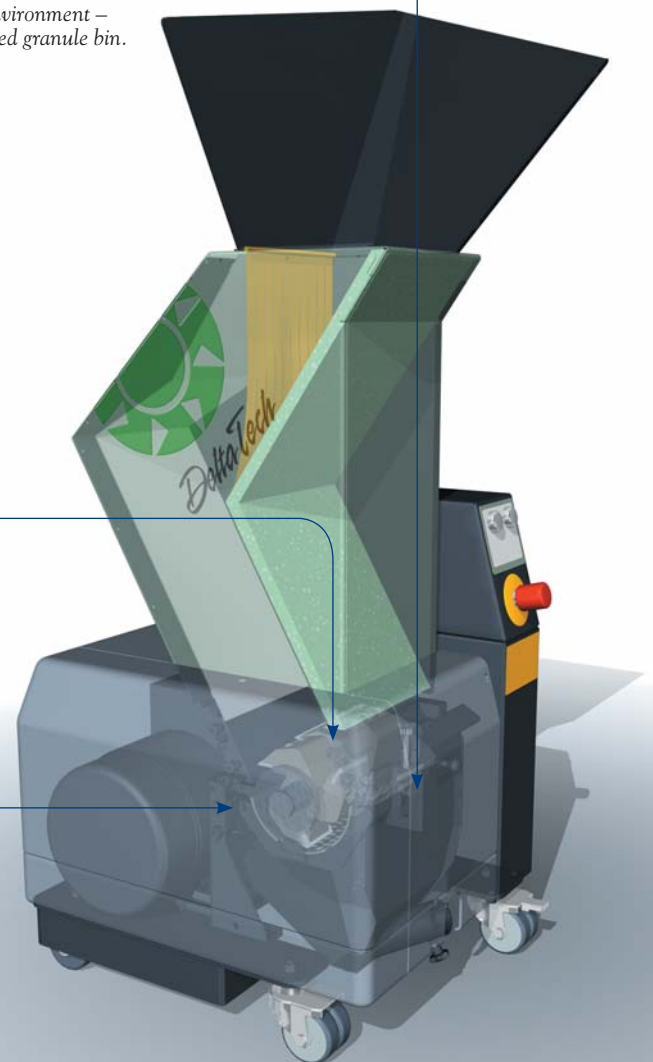

# Smart application solutions

## Small Rapid Auger 150-21 handles big sprues



The under-the-press Rapid Auger 150-21 forces even big and bulky sprues into the cutterhouse.

## Low and compact, high and ergonomic



The Rapid solutions for handling band conveyor feeding and high sprue picker/robot drop.

## Rapid 150 Docking demands minimal floor space



Super-low solution connected to the injection moulding machine. The docking function maintains safety. Brake motor as standard.

## Rapid Airveyor system and DS50 for material transport and dust separation



The Rapid solution for dust-generating materials and demanding processes in general, guarantees that regrind is always dust-free.

# World leaders in granulation



Rapid is the world leader in granulation. We develop, manufacture and market individual granulators and completely integrated recycling solutions for the plastics industry. With an extensive granulator range, from table-top units to giant machines, we can satisfy virtually all your granulation needs.

Our products are regarded as the most ruggedly built, most dependable and of the highest quality available on the market. That's why nearly all Rapid granulators come with a 5-year warranty. And our excellent 24/48-hour spare parts service helps to keep them in top condition.

We are dedicated to partnering with you. With over 50 years of experience, a global presence, and more than 60,000 units installed worldwide, we offer you our expertise, our people, and our resources.

Rapid strives to exceed your expectations in recycling plastic waste.



## Rapid Sweden – Head Office

Rapid Granulator AB  
Industrivägen 4, Box 9  
SE-330 10 Bredaryd, Sweden  
Phone: +46 (0)370 86500  
Fax: +46 (0)370 80251  
Email: [info@rapidgranulator.se](mailto:info@rapidgranulator.se)

## Present worldwide:

[info@rapidgranulator.com](mailto:info@rapidgranulator.com) (USA)  
[info@rapidgranulator.de](mailto:info@rapidgranulator.de) (Germany)  
[info@rapidgranulator.it](mailto:info@rapidgranulator.it) (Italy)  
[info@rapidgranulator.cn](mailto:info@rapidgranulator.cn) (China)  
[rapidsea@pacific.net.sg](mailto:rapidsea@pacific.net.sg) (Singapore)

## Representative: