



Rapid **150** PowerTech



Rapid 150 PowerTech line – For the toughest jobs.

The PowerTech line is specifically developed for filled and abrasive materials. It is optimized for long lasting wear resistance and top quality regrind, No compromises! The following headlines are some highlights of the PowerTech concept:

CleanGRIND Cutting technique

There are no short-cuts to the perfect regrind.

- Rapid has virtually perfected the art of processing high quality regrind. Consistent sized regrind with fewer fines that melts more uniformly. Recover your sprues without your production process and you'll feel the impact on the bottom line.

VersaGRIND Technology

- Specify the ideal granulator solution for your type and volume of plastic waste, granule size and recycling requirements. No compromises! Mix and match from Rapid's array of standardised options to create the granulator that exactly fits your application needs.

Easy CLEAN Engineering

- Easy cleaning and easy maintenance is fundamental demands for Rapid 150-Series. Instant access to all components provides easy cleaning when changing e.g. material or colours.

Cassette knife system

- The PowerTech-line is equipped with PowerTech knives with up to 13 times longer life-time.
- No re-sharpening! No re-adjustments! Just remove the worn knives and replace them with new ones. The knife clearance between rotating- and stator knife will automatically be correct!
- Make sure that you easily and quickly can service your granulator for long lasting durability and top quality regrind.

For the toughest jobs

Standard hopper

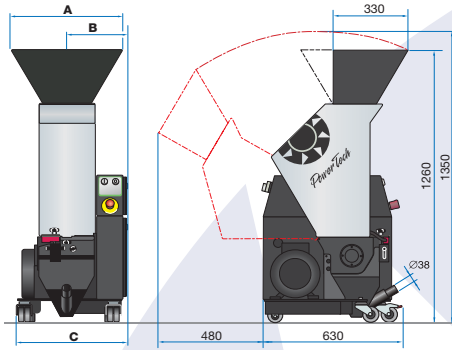

150-21 150-35 150-42

A	490	630	700
B	270	340	375
C	500	640	710

Hopper standard, base high-built

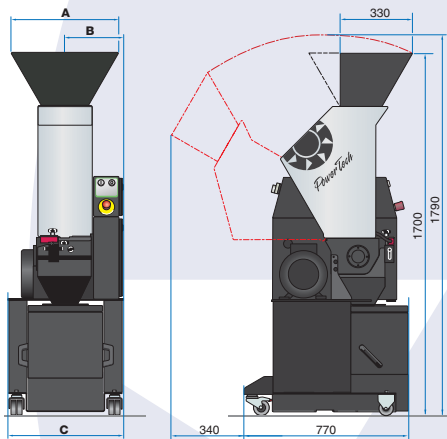

150-21 150-35 150-42

A	490	630	700
B	270	340	375
C	500	640	710

Hopper Z-feed, base low-built

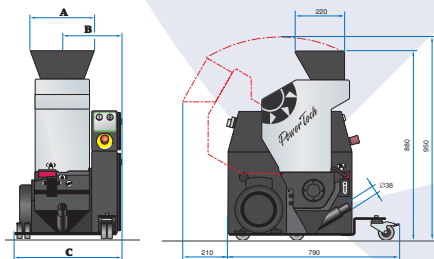

150-21 150-35 150-42

A	490	530	700
B	270	340	375
C	500	640	710

Rapid 150 PowerTech

	150-07 Mini	150-21	150-35	150-42
CUTTER HOUSE				
Opening, mm	80x70	210x150	350x150	420x150
inches	3 1/8x2 3/4	8 1/4x6	13 3/4x6	16 1/2x6
Fixed knives, no	2	2	2	2
Hardened rotor end disc	-	◆	◆	◆
Hardened cutter house	-	◆	◆	◆
ROTOR				
Staggered design	-	◆	◆	◆
Rotating knives	3x1	3x3	3x5	3x6
PowerTech knives	◆	◆	◆	◆
Scissor cut knives	◆	◆	◆	◆
Cassette knife system	◆	◆	◆	◆
Twin bearing	◆	◆	◆	◆
TRANSMISSION				
Motor 0.37 kW / 0.5 Hp	◆	-	-	-
Motor 2,2 kW / 3 Hp	-	◆	◆	◆
Motor 4 kW / 5.5 Hp	-	◇	◇	◇
Heavy duty transmission	◆	◆	◆	◆
HOPPERS				
Top feed/high built	◆	◆	◆	◆
Top feed/low built	-	◇	◇	◇
Rear feed	◆	◇	◇	◇
Removable flaps	-	◆	◆	◆
BASE				
Standard	◆	◆	◆	◆
High built	-	◇	◇	◇
Low built	-	◇	◇	◇
Low built electrical cabinet	-	◇	◇	◇
SCREEN				
Hole diam., mm/inches	4 / 5/32"	5 / 3/16"	5 / 3/16"	5 / 3/16"
Optional hole diam., mm	3, 5	3, 4, 6, 8		
inches	1/8", 3/16"	1/8", 5/32", 1/4", 5/16"		
Reversible screen	◆	◆	◆	◆
Hardened screen	-	◆	◆	◆
Stitch reduced screen	-	◇	◇	◇
Drop down screen cradle	◆	◆	◆	◆
REGRIND COLLECTION BIN				
Dust sealed	◆	◆	◆	◆
Diam 38 mm outlet	◆	◆	◆	◆
Adapter for sack filling	-	◇	◇	◇
Granule container 45 l	-	◇	◇	◇
Air veyor system	◇	◇	◇	◇
Level indicator capacitive type	-	◇	◇	◇
SAFETY				
Interlocking guard	Fixed	◆	◆	◆
PERFORMANCE				
Weight, kg	45	160	200	220
lbs	100	350	440	485
Throughput kg/h	<7	40	60	70
lbs/h	<15	90	130	150
Sound pressure level dB(A)	72-83 dB(A) depending on type of material, waste, feed rate, temperature, etc.			
OTHER OPTIONS				
Sound proof hood	◆	◇	◇	◇
Hour counter	◇	◇	◇	◇

◆ Standard, ◇ Optional, - not applicable

Mini model

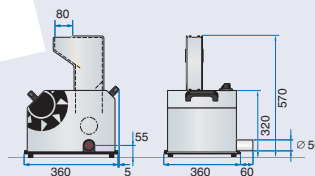

Rapid Granulator AB

Box 9, SE-330 10 Bredaryd, Sweden

Phone: +46 (0)370 86500 • Fax: +46 (0)370 80251

E-mail: info@rapidgranulator.se • www.rapidgranulator.se